

Verbal Suffix-Repetition Construction in Korean: A Constraint- and Construction-based Approach *

Saeyoun Cho and Nahyun Ku

Department of Linguistics, Kangwon National University,
1 Kangwondaehak-gil, Chuncheon-si Kangwondo 200-701, Korea
sycho@kangwon.ac.kr

Department of Linguistics, Kangwon National University,
1 Kangwondaehak-gil, Chuncheon-si Kangwondo 200-701, Korea
nine09ku@hanmail.net

Summary. There are various Verbal Suffix-Repetition (VSR) constructions in Korean, where suffixes such as *-kena/ tun(ci)/ tun(ka)* are attached to the repeated verbs. Calling the VSR Choice-denying Repeated Verbs construction, Lee (2011) claims that the following verb of the VSR, which can be replaced with *mal-*, should contain a negative but the preceding verb should be affirmative in the VSR construction which disallows any NPI within it. Unlike Lee (2011), we claim that the verbs in the VSR can freely occur either in the preceding position or in the following one regardless of their Neg value so long as they share the same verbal suffix forms such as *-tun(ka)*. Furthermore, NPIs may occur within the VSR construction if they occur with a negative predicate within the same clause. To implement the findings above into HPSG, we have proposed the two lexical entries for *mal-*, the VSR Construction Rule, and the NPI Clause-mate Constraint. **Sae-Youn Cho and Nahyun Ku. 2012. Verbal Suffix-repetition Constructions in Korean: A constraint- and Construction-Based Approach.**

Keywords: Verbal Suffix-Repetition construction, Choice-denying Repeated-Verbs, NPI, VSR Construction Rule, Clause-mate Constraint

2. Introduction

There are so-called “Verbal Suffix-Repetition (VSR)” constructions in Korean, where verbs in a CP functioning as a complement share the same suffixes such as *-kena/ -tun(ci) / -tun(ka)*, as follows:

- (1) [Marcia *-ka* kyelhon-ul ha-**tun** an-ha-**tun**], na-nun kwansim-epse.
M-Nom marry-Acc do-Suf Neg-do-Suf, I-Top care-Neg
‘Whether Marcia marries or not, I don’t care.’

Recently, Lee (2011) argues that the VSR construction functioning as a complement should be dealt with differently from that functioning as an adjunct in the sense that comparing to the

* We are grateful to Prof. Jung-Min Lee, Jong-bok Kim for valuable comments, and we wish to thank the anonymous reviewers of HPSG 2012 for discussion and comments.

latter, the former exhibits quite different properties: he claims that the preceding verb in the repeated verbs of the VSR should be affirmative but the following one, negative, assuming that sentence (2) where the preceding verb with a negative precedes an affirmative verb, *an-ha-tun ha-tun*, is ungrammatical. Further, he suggests that the following verb can be replaced with *mal-* in terms of either the operation ‘copy & delete’ or ‘substitution’ as in (2).

- (2) [Marcia –ka kyelhon-ul **an-ha-tun ha-tun* / *ha-tun mal-tun*],
 M-Nom marry-Acc Neg-do-Suf do-Suf do-Suf, not do-Suf
 ‘Whether Marcia marries or not, I don’t care.’

In doing so, he argues that any NPI (Negative Polarity Item) cannot occur within the VSR CP on the basis of the fact that (3) is ungrammatical:

- (3) *[Ney-ka *amwuto* manna-**tunka** an-manna-**tunka** / *mal-tunka*],
 You-Nom none (NPI) meet –Suf Neg-meet-Suf / not do-Suf
 ‘Whether you meet none or not’

However, the fact that sentences like (4) where the VSR, exhibiting the reverse sequence, namely negative verb + affirmative verb, contains an NPI within the clause are construed to be grammatical seems to be a puzzle to Lee (2011):

- (4) [Ku phathi-ey **amwuto an-o-tunci** mal-tunci]
 The party-Loc none Neg-come-Suf stop-Suf
 ‘Whether no one comes to the party or not’

Unlike Lee (2011), we claim here that the verbs in the VSR can freely occur either in the preceding position or in the following one regardless of their Neg value so long as they share the same verbal suffix form. Further, NPIs such as *amwuto* may occur within the VSR construction if they occur with a predicate containing a negative within the same clause.

To support our claim, we provide various properties of the VSR construction especially as to the possibilities of the occurrence of the verbs in the construction with respect to the value of Neg, the characteristics of *mal-* and the distributional behaviors of NPIs in the VSR in Section 2. We propose a constraint- and construction-based analysis of the VSR construction and then demonstrate how it works in Section 3. In conclusion, we suggest the consequences of our theory.

2. Properties of the VSR Construction

2.1. The Possible Verb Sequences in the VSR

Logically, the verb sequences in the VSR construction, schematized as $_{CP} [\dots V+\alpha V+\alpha]$, can be realized in four ways with respect to the existence of a negative as follows:

- (5) a. Pattern I: $_{CP} [\text{affirmative } V+\alpha \text{ affirmative } V+\alpha]$
 b. Pattern II: $_{CP} [\text{affirmative } V+\alpha \text{ negative } V+\alpha]$
 c. Pattern III: $_{CP} [\text{negative } V+\alpha \text{ affirmative } V+\alpha]$

d. Pattern IV: $_{CP}[\text{negative V}+\alpha \text{ negative V}+\alpha]$
 (Where α stands for the suffixes such as *-kena/ -tun(ci) / -tun(ka)*)

Pattern I is basically possible unless the repeated verbs are identical. If the following repeated verb is the exact same morphological form of the preceding verb, it will be ill-formed as in (6).

- (6) [Tangsin-i pap-ul **mek-tun** capsusi-tun/ ***mek-tun**],
 You-Nom rice-Acc eat-Suf eat-HON-Suf eat-Suf
 ‘Whether you eat rice or not’

As for Pattern II, as Lee (2011) has argued, there is no discrepancy, in grammaticality at least, on this pattern. Against Lee’s claim, however, we can find sentences like (7) belonging to the Pattern III and sentences like (8) belonging to the Pattern IV in the Korean Corpus data, *Hanmaru Search Engine of 21 Sejong Project*, which means they are grammatical.

- (7) [An-pwa-essten mwuncey **i-tun** pwa-essten mwuncey **i-tun**],
 Neg-saw problem be-Suf saw problem be-Suf
 ‘Whether you have seen this question or not’ (6CM00002)

- (8) [**An-hanunke-ten mos-hanunke-ten**],
 Neg-do-Suf Neg-can do-Suf
 ‘Whether he doesn’t want to do it or can’t do it’ (6CM00054)

Throughout the observations, the four sequence patterns in the VSR construction exhibit the following properties:

- (9) A. The verbs in the VSR can freely occur either in the preceding position or in the following one regardless of their Neg value so long as they share the same verbal suffix form.
 B. When affirmative verbs repeat, they should have different morphological forms.
 C. When negative verbs repeat, negative affixes should be different.

2.2. The Characteristics of *Mal-* and the Distributional Behaviors of NPIs in the VSR

As for the verb *mal-*, Lee (2011) suggests that *mal-* can be realized either by the operation “copy & delete” or by substituting the repeated verb in the VSR. The process, copy & delete, however, appears to face difficulties deriving *mal-tunci* because input strings like **yeyppuci-mal-tunci* ‘pretty-not-Suf’ are ill-formed. Similarly, the substitution operation to get *mal-* in the VSR also seems to undergo difficulties deciding the counterpart input. For example, it is unclear how the string, *an-ka-tunka mal-tunka* ‘not go or not not go’, can be derived under this operation.

Throughout the reviewing of the demerits of the two approaches to *mal-*, we conclude that there are at least two different functions of ‘*mal-*’s in Korean: *mal-1* and *mal-2*. The characteristics of the *mal-*s are summarized as follows:

- (10)

	Form	Meaning	
(10)	<i>Mal- 1</i> <i>V-ci malta</i> [+Neg]		to stop or deny the event referred to by the preceding verb

Mal-2 *V- α mal- α* to refer to all the events except for that referred to by the
 [β Neg][β Neg] preceding verb
 (Where α stands for suffixes such as *-tunci* and β , the Neg value.)

As shown in (10), unlike Lee (2011), the *mal-2* in the VSR semantically does not deliver the message of denying the event referred to by the preceding verb. Rather, it refers to all the events except for that referred to by the preceding verb. Thus, we conclude that the meaning of the VSR essentially is the list of events referred to by the repeated verbs in the construction.

According to Lee (2011), the NPI, *amwuto*, cannot appear with an affirmative verb so that both examples belonging to Pattern I and II are predicted to be ungrammatical. However, the fact that the Pattern III and IV, in which the preceding verb contains a negative, are possible cannot be explained under his analysis, since he regards such patterns as ill-formed. We propose that the preceding verb and the following one of the VSR may have a bi-clausal structure or constitute a syntactic compound while the preceding verb and the *mal-2* constitutes a syntactic compound only. If this proposal is adopted, (4) is correctly predicted to be grammatical because the preceding negative verb and *mal-2* constitute a syntactic compound so that the NPI and the negative verb co-occur within a clause, resulting in the observing of the Clause-mate Constraint.

3. A Constraint- and Construction-based Analysis

To implement such observations into current HPSG, we postulate a construction rule for the VSR and a few lexical constraints on *mal-*, assuming the Clause-mate constraint to treat the distributional behaviors of NPIs. First, we posit the following lexical entries for *mal-*:

(11) *mal-1*:

$$\langle mal-, \left[\begin{array}{l} \text{SYN} \left[\begin{array}{l} \text{HEAD} \left[\begin{array}{l} \text{POS } verb \\ \text{VFORM } \alpha \\ \text{AUX } + \\ \text{NEG } + \end{array} \right] \\ \text{VAL} \left[\begin{array}{l} \text{SPR } \langle \square \text{NP} \rangle \\ \text{COMPS } \langle \square \text{VP} \rangle \left[\begin{array}{l} \text{VFORM } - ci \\ \text{SPR } \square \\ \text{SEM } | \text{INDEX } S_1 \end{array} \right] \end{array} \right] \end{array} \right] \right] \\ \text{ARG} - \text{ST } \langle \square, \square \rangle \\ \text{SEM} \left[\begin{array}{l} \text{MODE } prop \\ \text{INDEX } S_0 \\ \text{RESTR } \langle \text{ARG } S_1 \rangle \\ \text{SIT } S_0 \end{array} \right] \end{array} \right] \rangle$$

(12) *mal-2*:

$$\langle mal-, \left[\begin{array}{l} \text{SYN} \left[\begin{array}{l} \text{HEAD} \left[\begin{array}{l} \text{POS } verb \\ \text{VFORM } \alpha \\ \text{AUX } + \\ \text{MC } - \\ \text{NEG } \beta \end{array} \right] \\ \text{VAL} \left[\begin{array}{l} \text{SPR } \langle \square \square \square \rangle \\ \text{COMPS } \langle \square \square \square \rangle \left[\begin{array}{l} \text{VFORM } \alpha \\ \text{NEG } \beta \\ \text{VAL} \left[\text{SPR } \langle \square \square \rangle \right] \\ \text{SEM } \mid \text{INDEX } S_1 \end{array} \right] \end{array} \right] \end{array} \right] \\ \text{ARG} - \text{ST } \langle \square, \square \rangle \\ \text{MODE } prop \\ \text{INDEX } S_0 \\ \text{SEM} \left[\begin{array}{l} \text{RESTR } \left\langle \begin{array}{l} \text{ARG } \forall S V \neg S_1 \\ \text{SIT } S_0 \end{array} \right\rangle \\ \text{RELN } be - listed \end{array} \right] \end{array} \right] \rangle$$

(Where MC stands for Main Clause)

Assuming the Clause-mate constraint in (13) to deal with NPIs, we postulate the “VSR construction rule” in (14) which enables us to obtain a syntactic compound. The VSR, however, in which it does not satisfy the constraints in (14) can be regarded as a bi-clausal structure. In this case, the bi-clausal structures can be generated in terms of the Coordination Rule in HPSG.

(13) **The NPI Clause-mate Constraint** (Informal Version):

NPIs as a functor in the *head-functor* structure select a head with [NEG +] within a clause.

(14) **The VSR Construction Rule (A Syntactic Compound Rule) :**

$$v \left[\begin{array}{l} \text{HEAD} \left[\begin{array}{l} \text{VFORM } \alpha \\ \text{NEG } \beta \end{array} \right] \\ \text{VAL} \quad \square \end{array} \right] \Rightarrow v \left[\begin{array}{l} \text{HEAD} \left[\begin{array}{l} \text{VFORM } \alpha \\ \text{NEG } \beta \end{array} \right] \\ \text{MORPH } \mid \text{STEM } \gamma \\ \text{VAL} \quad \square \end{array} \right] \quad v \left[\begin{array}{l} \text{HEAD} \left[\begin{array}{l} \text{VFORM } \alpha \\ \text{NEG } \beta \end{array} \right] \\ \text{MORPH } \mid \text{STEM } \delta \\ \text{VAL} \quad / \square \end{array} \right]$$

(Where $\alpha \in \{-kena, -tun(ci), tun(ka)\dots\}$, β can have \pm value, γ and δ stand for verbal values.)

Once these tools are adopted in HPSG, the properties of the VSR construction can be sufficiently accounted for. To show this is so, we demonstrate how our theory analyzes the VSR construction with an NPI in a clause.

The strings like *amwuto an-o-tunci mal-tunci* as the second type of the Pattern III with an NPI can be represented as follows:

(15)

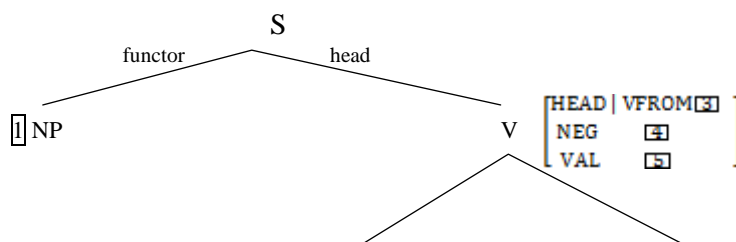

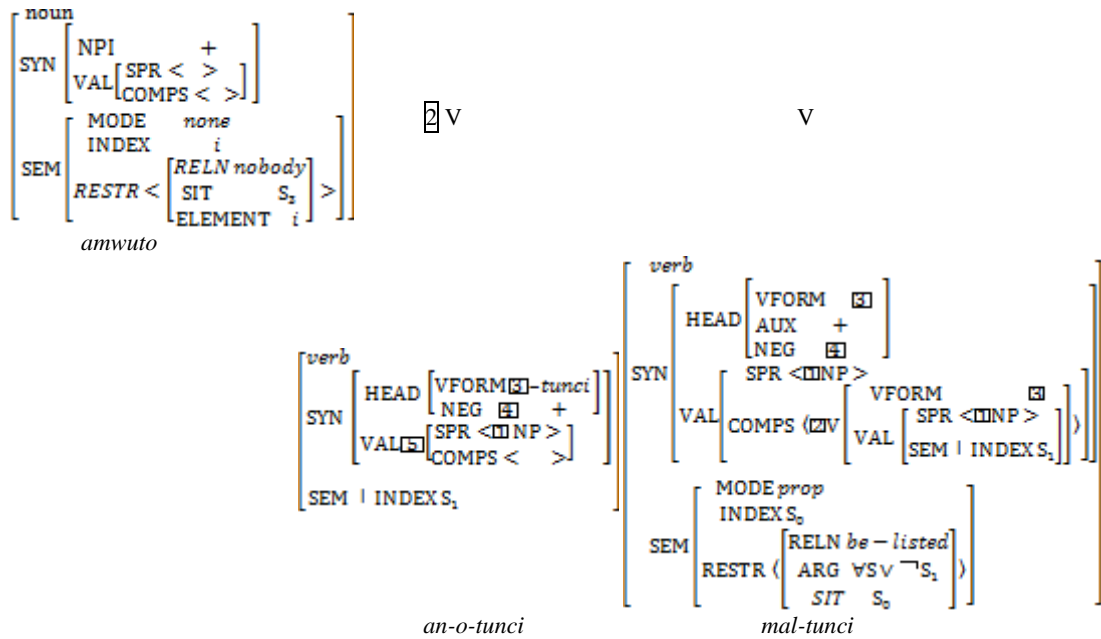

The local tree in the bottom part is licensed as a syntactic compound in terms of the VSR rule and the lexical information of *mal-2*. Since the NEG value of the mother in the local tree is positive (+), the NPI in the top local tree of the clause satisfies the Clause-mate Constraint. Hence, the strings are well-formed. In addition to the syntactic parts, the semantic RELN (relation) of *mal-tunci* in (15) is *be-listed* and its ARG (argument) is all situations (events) except the situation referred to by the preceding verb *an-o-tunci*, i.e. $\forall S \& \neg S_1$.

The last example we demonstrate is the strings like *amwuto an-o-tunci mos-o-tunci* as one of Pattern IV examples with an NPI which can be represented as follows:

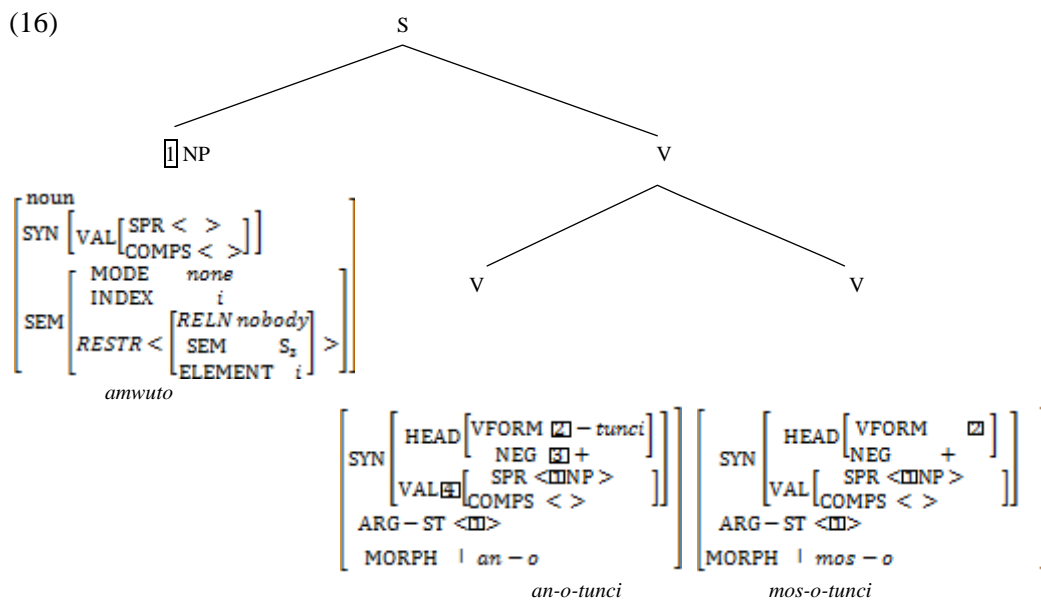

When the NPI occurs with the two negative verbs in a bi-clausal structure, the strings are predicted to be well-formed because the NEG value of each verb is positive so that they can observe the Clause-mate Constraint. In a syntactic compound, the strings are also regarded as legal since both negative verbs share the same NEG value, +.

4. Conclusion

Unlike Lee (2011), we claim here that the verbs in the VSR can freely occur either in the preceding position or in the following one regardless of their Neg value so long as they share the same verbal suffix forms such as *-tun(ka)*. Furthermore, NPIs may occur within the VSR construction if they occur with a negative predicate within the same clause. To support our claim, we have shown that the repeated verbs can freely occur regardless of the Neg value and NPIs also appear in the VSR. To implement the findings above into HPSG, we have proposed the two lexical entries for *mal-*, the VSR Construction Rule, and the Clause-mate Constraint. These tools enable us to account for the idiosyncratic properties of the VSR constructions under this constraint- and construction-based approach. In fact, our analysis can be extended to analyze the VSR functioning as an adjunct with no additional tool. Consequently, we suggest that the VSR proposed by Lee (2011) should be merely a subtype of the VSR constructions in Korean.

References

- Lee, J-S. 2011. Choice-denying repeated-verbal. *Linguistics*: 19-3. 233-249.
- Sag, I., T. Wasow, and E. Bender. 2003. *Syntactic Theory: A Formal Introduction*, the 2nd edition. CSLI Publications.